

COMPRESSED AIR BALL FLOAT TRAPS FA32 (Carbon Steel)

DESCRIPTION

The FA32 compressed air float trap series are specially designed for draining water from high pressure compressed air and gas lines. Usual applications include aftercoolers, separators and compressed air and gas mains. An air balance pipe must be fitted, to allow the air trapped in the FA32 body to escape, avoiding obstructing the condensate flow.



MAIN FEATURES

Modulating discharge.
Unaffected by sudden or wide load and pressure changes.

OPTIONS: Equalizing and drain plug on body.
Lifting lever.

USE: Compressed air and non corrosive gases compatible with the construction.

AVAILABLE MODELS: FA32 – 21, FA32 – 32.

SIZES: 1"; DN 25.

CONNECTIONS: Female threaded ISO 7 Rp.
Flanged EN1092-1 PN40 or ANSI B16.5 Class 150 lb or 300 lb.
Special flanges upon request.

INSTALLATION: Horizontal or vertical installation.

APPLICATION LIMITS	
Min. liquid specific weight	0,75 kg/dm ³
Maximum working diff. press. – FA32-21	21 bar
Maximum working diff. press. – FA32-32	32 bar

CE MARKING – GROUP 2 (PED – European Directive)	
PN40	Category
1"; DN 25	SEP

BODY LIMITING CONDITIONS		
FLANGED PN40 / ANSI 300 lb *	FLANGED ANSI 150 lb**	RELATED TEMPERATURE
ALLOW. PRESS.	ALLOW. PRESS.	
37,1 bar	17,7 bar	100 °C
33,3 bar	14 bar	200 °C
30,4 bar	12,1 bar	250 °C
27,6 bar	10,2 bar	300 °C

PMO – Max. operating press. 32 bar;

TMO – Max. operating temp. 200 °C;

* According to EN1092-1:2018; ** According to EN1759-1:2004;

Body limiting conditions PN40 or below, depending on the type of connections adopted. Rating PN40 for thread, SW and BW.

FLOW RATE CAPACITY (kg/h)																
MODEL	SIZE	DIFFERENTIAL PRESSURE (bar)														
		1	1,5	2	3	4,5	6	7	8	9	10	12	14	16	21	32
FA32 – 21	1"; DN 25	410	500	600	710	900	1005	1100	1150	1200	1350	1550	1640	1700	1850	–
FA32 – 32	1"; DN 25	240	280	335	400	500	590	610	690	700	745	850	900	920	1100	1380

DIMENSIONS (mm)

SIZE	THREADED							PN16/40			PN16/40 *			ANSI 150 lb			ANSI 150 lb *			ANSI 300 lb			ANSI 300 lb *		
	A	B	C	D	E	H	WT. (kg)	F	G	WT. (kg)	F	B	WT. (kg)	F	G	WT. (kg)	F	B	WT. (kg)	F	G	WT. (kg)	F	B	WT. (kg)
1 – DN 25	120	195	80	190	110	1/4" **	9	160	248	11,3	230	195	12	160	248	11	230	195	11,2	160	248	11,3	230	195	12,8

* Alternative; ** Threaded NPT.

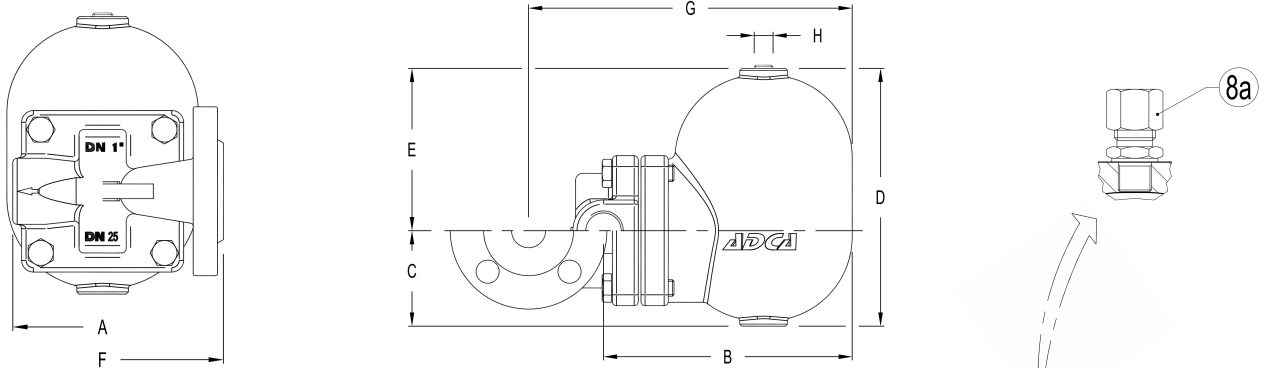

MATERIALS

POS. N°	DESIGNATION	MATERIAL
1	Body	GP240GH / 1.0619
2	Cover	GP240GH / 1.0619
3	* Gasket	Stainless steel / Graphite
4	* Seat	AISI 410 / 1.4006
5	* Valve	Viton
		AISI 440C / 1.4125
6	* Lever	AISI 304 / 1.4301
7	* Float	AISI 304 / 1.4301
8A	** Compression fitting	Stainless steel or Steel Fe/Zn
9	Bolts	Steel 8.8

* Available spare parts.; ** Optional, against extra price.

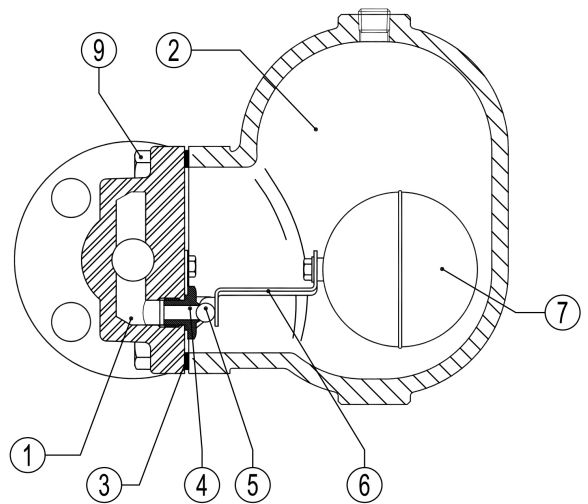

TYPICAL INSTALLATION

